

Arc Welder

I. Competencies

Given a functional welder, instruction and demonstration of use, each student will be able to:

- A. Identify the major parts of the arc welder.
- B. Pass a written test of safety and operating procedures of the arc welder with a minimum of 100 percent accuracy.
- C. Demonstrate, to the satisfaction of the instructor, ability to safely use an arc welder while performing assigned tasks.

II. Instructional Materials and Procedures

A. Identification of Basic Arc Welder Parts

- | | |
|------------------------------|----------------------------------|
| 1. Switch | 7. Amperage adjustment handwheel |
| 2. Power cord | 8. Helmet |
| 3. Ground cable terminal | 9. Electrode holder |
| 4. Amperage output indicator | 10. Electrode cable terminal |
| 5. Ground clamp | |
| 6. Polarity switch | |

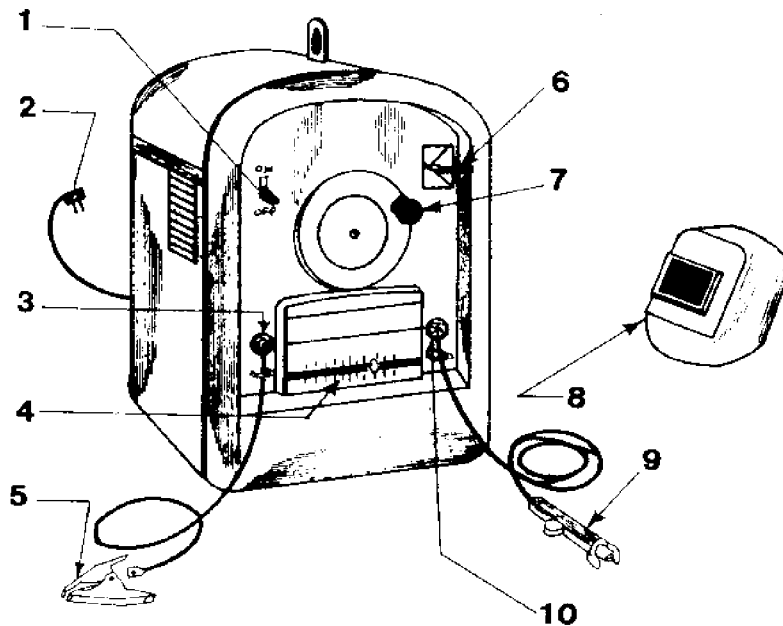

B. Arc Welder Safety

1. Always wear protective clothing suitable for welding. Wool or cotton clothing, high top leather shoes, gauntlet gloves, welding apron or leathers, and leggings are recommended. DO NOT wear clothing made of synthetic fibers when welding. Some synthetic fibers are highly flammable.
2. Always wear industrial quality eye protection when welding and cleaning welds. A number 10 filter lens is minimum for most arc welding processes.
3. Keep the welding area clean and free of tools, scrap metal, and water.
4. Make sure the work area is free of flammable, volatile, or explosive materials. (Ex. propane, gasoline, grease, and coal dust).
5. Do not carry matches, butane or propane lighters or other flammables in you pockets while welding.
6. Shield others from the light rays produced by arc welding. Keep the welding curtain in place at all times.
7. Never weld while standing in water or on damp ground.
8. Guard against the use of damp or wet clothing when welding. The use of such clothing increases the possibility of electrical shock.
9. Never breath fumes when welding lead, cadmium, chromium, steel, manganese, brass, bronze, beryllium, zinc, or galvanized steel. These fumes are toxic and may cause sickness or death. A good exhaust system is essential when welding within a confined laboratory.
10. Protect welding cables from sparks, hot metal, open flames, sharp edges, oil, and grease.
11. Never lay the electrode holder on the welding table or a grounded metal surface. Place it on an insulated hanger. An electrode holder should never touch a compressed gas cylinder.
12. Place electrode stubs in a suitable container. Do not allow stubs to get on the floor in the welding area.
13. Use tongs or pliers to handle hot metal after it has been welded. Completely submerge metal in water when cooling, this prevents steam from burning you.

14. Never weld with the cables coiled over the shoulders.
15. Disconnect the power to a welding machine before making any repairs.
16. Treat all cuts or burns promptly. Report accidents to the instructor immediately; treat any cuts or burns promptly.
17. Cool and store any hot metal before leaving the work area.
18. Do not use cables with frayed, cracked or bare spots in the insulation.
19. Use a fire blanket to smother clothing fires. Use a dry chemical type “C” extinguisher to put out an electrical fire.

C. Arc Welder Operating Procedures

1. Check to make sure the welding machine is properly grounded. The welding equipment should be installed according to provision of the National Electric Code and the manufacturers recommendations.
2. A power disconnect switch should be conveniently located near each welding machine.
3. Turn the welder off and store cables before leaving the welding area.
4. The operator should keep all cable connections tight.
5. Inspect electrode holders for defective jaws and poor insulation.
6. Make adjustments in polarity and amperage only when the machine is not under load. Switching the current while the machine is under load will cause an arc to form between the contact surfaces.
7. Wear a welding helmet with a correct shade filter lens. A number 10 to 12 filter lens is usually satisfactory for general purpose welding. Most welding helmets provide a flip-up device to allow chipping or grinding to be done without removing the helmet.
8. Keep welding screens in place to protect on-lookers from arc flash.
9. Turn on the fumes removal system before starting to weld.
10. Do not weld in damp areas; keep hands and clothing dry at all times. Dampness on the body increases the chance of electrical shock when welding.

11. Do not weld in areas that store compressed gas cylinders.
12. Be sure that all gas cylinders are chained in an upright position before starting to weld.
13. Clear all combustible materials from the welding area before welding.
14. Handle all compressed gas cylinders used in Mig and Tig welding with extreme care. Keep the cylinder caps in place when the cylinders are not in use.
15. When gas cylinders are empty, close the valve and mark cylinders “empty”.
16. When using water cooled equipment, check for water leakage often.
17. Use an audible signal such as “cover” to indicate to others that you plan to strike an arc.
18. If an electrode sticks, try to twist it free. If twisting fails to free the electrode, release the electrode from the electrode holder. Turn off the switch on the welder and use pliers to break the electrode free.
19. Avoid welding directly on concrete floors. Residual moisture in the concrete may be turned to steam resulting in the concrete exploding.